

TYPE R50

FUNCTION

The belt bend conveyor is especially suitable for smooth and accurate transport of unpacked and packed products in the food and non-food processing industry. The proven design ensures high productivity and availability in multi shift operation. The modular design allows for a vast range of combinations of belt width and outer radius. The angle of the conveyor typically varies between 30° (depending on size) and 180°. The R50D has a maximum load of ± 35 kg.

CHARACTERISTICS

- ▶ Compact modular design, fits in virtually any space situation
- ▶ Mild steel, coated in RAL colour of choice
- ▶ Highly reliable
- ▶ Low noise level (varies with speed / belt type)
- ▶ Low maintenance requirement and costs
- ▶ Easy belt replacement

DESCRIPTION

The belt bend conveyor is used in various applications such as in:

- ▶ Food processing industry
- ▶ Packaging lines for pharmaceuticals, cosmetics, chemicals
- ▶ Sorting and order picking systems
- ▶ Paper- and printing industry
- ▶ Agriculture

The conveyor is supplied with a closed plate to support the entire belt track. The support frame consists of square profiles and has height adjustable feet.

The belt is guided by a series of roller sets mounted on the outer radius of the belt. Each roller set consists of two ball bearings, axial mounted on nylon strip seizing the belt. This ensures optimum belt guidance, low noise level and low maintenance.

The belt is endless jointed. The multi-layer belt has a top layer of PVC or PU. The conical rollers are frame mounted with adjustable bearing units. The drive roller is coated with high friction material.

The drive is shaft-mounted at the inner radius or optional at the outer radius.



TYPE R50

TECHNICAL SPECIFICATIONS

Angle	30° - 180°
Max. outer radius	1.700 mm
Max. belt width	900 mm
Min. height*	100 mm
Frame - belt height	≤ 1.000 mm, ± 50mm adjustable
Max. load	35 kg
Max. conical roller diam.	50 mm outside radius
Belt type	PVC/PU, 2 ply
Execution	Mild Steel, coated
Power supply	400V, 0,25/0.37/0,55 kWh, 50 Hz, 3Ph+0+PE
Max. belt speed	50 m/min at centre of belt (depending on size)
Drive	SEW Eurodrive, shaft-mounted
Protection class	IP54

* Shaft-mounted gear, belt pulling and mounted at inside / outside radius.

OPTIONS

Conveyor / Support frame

- ▶ Stainless steel, AISI 304, Finish 2B
- ▶ Tailor made support frame
- ▶ Support wheels with brake

Angle

- ▶ Non standard angles, specified in degrees

Drive

- ▶ SEW Movimot™ Integrated frequency inverter
- ▶ Protection classes IP56/IP65 for SEW drive
- ▶ Other type of drive, without drive

Belt type

- ▶ Belt type on demand
- ▶ Belt with integrated spill rim or combined with a seal at outer radius

Accessories

- ▶ Product guiding rail(s)
- ▶ GT-closure and/or Labyrinth closure

DIMENSIONS AND NOTATIONS

		Outer radius in mm												
*		1700	1600	1500	1400	1300	1200	1100	1000	900	800	700	600	500
Useful belt width in mm*	900	✓	✓	✓										
	800	✓	✓	✓	✓									
	700	✓	✓	✓	✓	✓	✓							
	600	✓	✓	✓	✓	✓	✓	✓	✓					
	500	✓	✓	✓	✓	✓	✓	✓	✓	✓	✓			
	400	✓	✓	✓	✓	✓	✓	✓	✓	✓	✓	✓		
	300	✓	✓	✓	✓	✓	✓	✓	✓	✓	✓	✓	✓	✓
	200	✓	✓	✓	✓	✓	✓	✓	✓	✓	✓	✓	✓	✓

*Non-standard belt width: on request

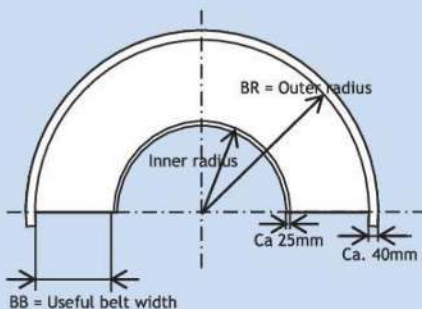

R50D/BR/BB/L./UV

Execution	: Mild Steel, coated or Stainless steel
Angle	: Standard 90° / 180°.
Useful belt width	: mm
Outer radius	: mm
Type belt bend conveyor	: R50D, R70D